



Basic socket series designation for: \_\_\_\_\_

JCL

Meets the requirements of: \_\_\_\_\_

MIL-S-12883

## SOCKET DRAWING

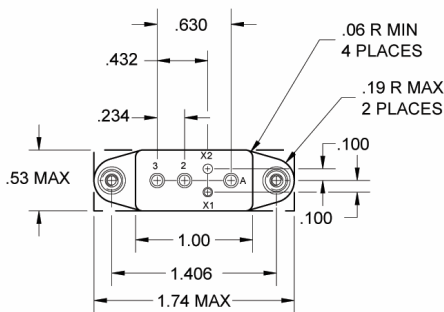

## HARDWARE MOUNTING

MOUNTING DETAIL 2 PLACES

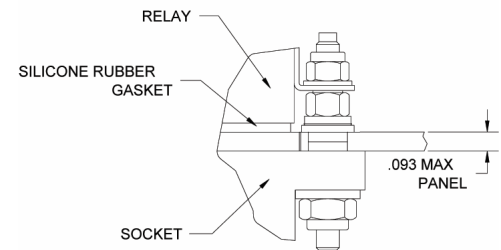

## MOUNTING DIMENSIONS

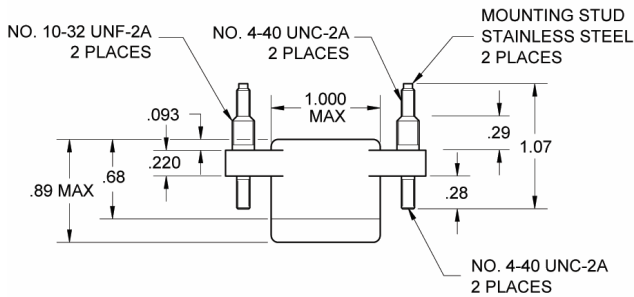
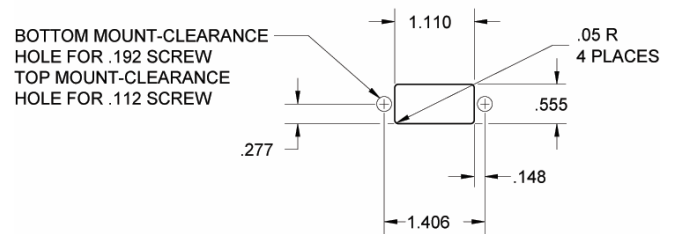

## GENERAL CHARACTERISTICS

Supplied with mounting hardware and No. 12 contacts and crimp for power terminals; No. 16 contacts and crimp for X coil; No. 22 contacts and crimp for Y coil.

Temperature range: -70° C to +125° C

Weight: .060 lbs. max

Standard tolerances: .xx ±.01; xxx ±.005